

PRODUCT INFORMATION PACKET

Model No: 256TTGN16509

Catalog No: E505

20 HP Explosion Proof Motor, 3 phase, 3600 RPM, 230/460 V, 256T Frame, EPFC
Explosion Proof NEMA Motors





Nameplate Specifications

Output HP	20 Hp	Output KW	14.9 kW
Frequency	60 Hz	Voltage	230/460 V
Current	47.0/23.4 A	Speed	3537 rpm
Service Factor	1.15	Phase	3
Efficiency	92.4 %	Power Factor	86
Duty	Continuous	Insulation Class	F
Design Code	B	KVA Code	G
Frame	256T	Enclosure	Explosion Proof Fan cooled
Thermal Protection	Thermostats (N/C)	Ambient Temperature	40 °C
Drive End Bearing Size	6309	Opp Drive End Bearing Size	6210
UL	UL Listed And CSA Certified	CSA	Y
CE	N	IP Code	54
Hazardous Location	EXP PROOF CL I GR C&D CL II GR F&G T3B		

Technical Specifications

Electrical Type	Squirrel Cage Inverter Rated	Starting Method	Line Or Inverter
Poles	2	Rotation	Reversible
Resistance Main	.394 Ohms	Mounting	Rigid base
Motor Orientation	Horizontal	Drive End Bearing	Ball
Opp Drive End Bearing	Ball	Frame Material	Cast Iron
Shaft Type	T	Overall Length	25.27 in
Frame Length	12.25 in	Shaft Diameter	1.625 in
Shaft Extension	4.18 in	Assembly/Box Mounting	F1 ONLY
Outline Drawing	B-SS203001-1225	Connection Drawing	A-EE7308AD

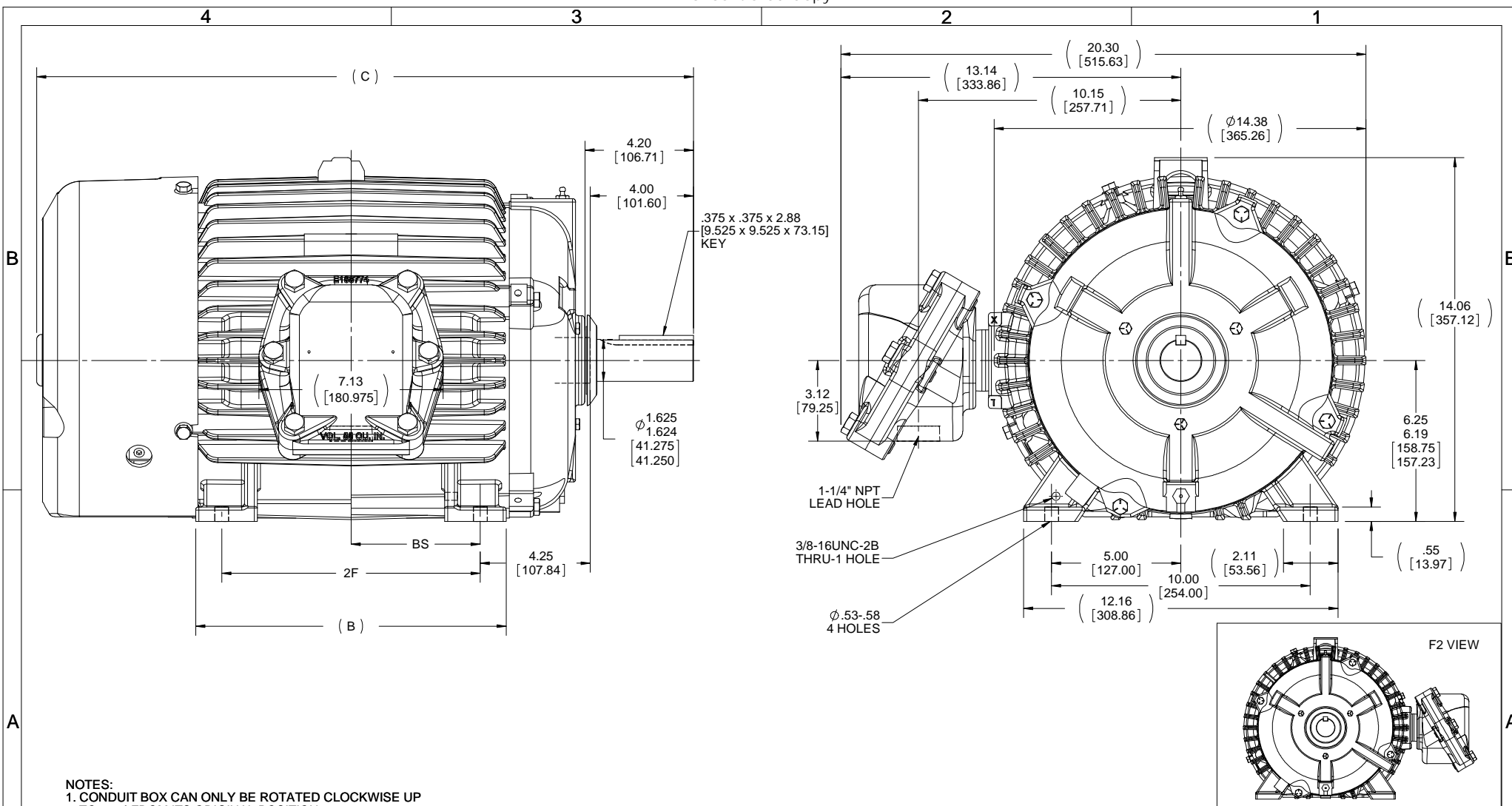

NOTES:
 1. CONDUIT BOX CAN ONLY BE ROTATED CLOCKWISE UP TO 270° FROM ITS ORIGINAL POSITION.
 2. NAMEPLATES TO BE READ FROM CONDUIT BOX SIDE OF MOTOR.

DASH	FRAME	B	C	2F	2FF	BS
1050	254T	10.25 [260.35]	23.65 [600.71]	---	8.25 [209.55]	4.12 [104.65]
1225	256T	12.00 [304.80]	25.40 [645.16]	---	10.00 [254.00]	5.00 [127.00]

DRAWING REVISION F	REVISION BY SD	DATE 11/18/2019
ECO-0177002	APPROVED BY VMR	DATE 11/18/2019
ECO DESCRIPTION OUTLINE DESCRIPTION AND C DIMENSION UPDATED		
<small>COPYRIGHT REGAL BELOIT AMERICA, INC. ALL RIGHTS RESERVED. PROPRIETARY AND CONFIDENTIAL INFORMATION - THIS DOCUMENT IS THE PROPERTY OF REGAL BELOIT AMERICA, INC. ("OWNER") AND CONTAINS OWNER'S PROPRIETARY INFORMATION. ANY PERSON, CORPORATION OR OTHER FIRM RECEIVING IT IS DEEMED, BY RECEIVING IT, TO AGREE THAT IT, AND/OR ANY PART OF IT, SHALL NOT BE DISCLOSED TO ANY PERSON, CORPORATION OR OTHER ENTITY, DUPLICATED, AND/OR USED, EXCEPT AS EXPRESSLY APPROVED IN WRITING IN ADVANCE BY OWNER. THIS DOCUMENT SHALL BE RETURNED TO OWNER UPON REQUEST. IT MAY BE SUBJECT TO CERTAIN RESTRICTIONS UNDER APPLICABLE EXPORT CONTROL LAWS AND REGULATIONS.</small>		

TOLERANCES UNLESS OTHERWISE SPECIFIED:			
DEC.	INCH	mm	ANGLE
.X	+0.1	[+2.5]	±7-30°
.XX	+0.03	[+0.76]	
.XXX	+0.005	[+0.127]	
.XXXX	+0.0005	[+0.0127]	
REMOVE BURRS & BREAK SHARP EDGES: .003/.015 [0.076/.381]			
CORNER FILLETS: .02 [0.51]			
MACHINED SURFACES: 200 INCH/mm 5.1			
mm SHOWN IN [BRACKETS]			

DRAWN BY RM	DATE 12-14-1993
APPROVED BY FG	DATE 12-15-1993
REFERENCE	
THIRD ANGLE PROJECTION	

REGAL™ Regal Beloit America, Inc.

DESCRIPTION
OUTLINE
250T FR. EXP. PR. - BB - T - STD.

MATERIAL

PROCESS/FINISH

SIZE **B** DRAWING NUMBER **SS203001** SHEET **1 OF 1**

LOW VOLTAGE

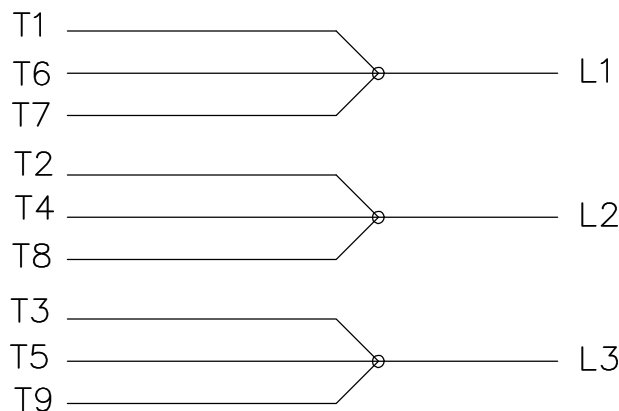

HIGH VOLTAGE

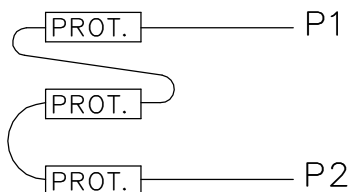
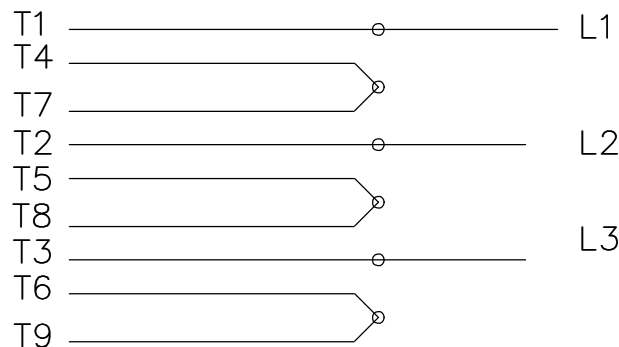

LOW VOLTAGE

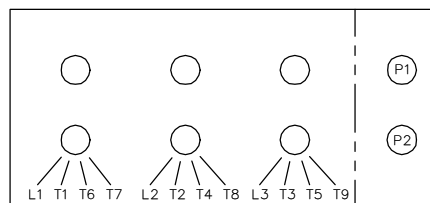

HIGH VOLTAGE

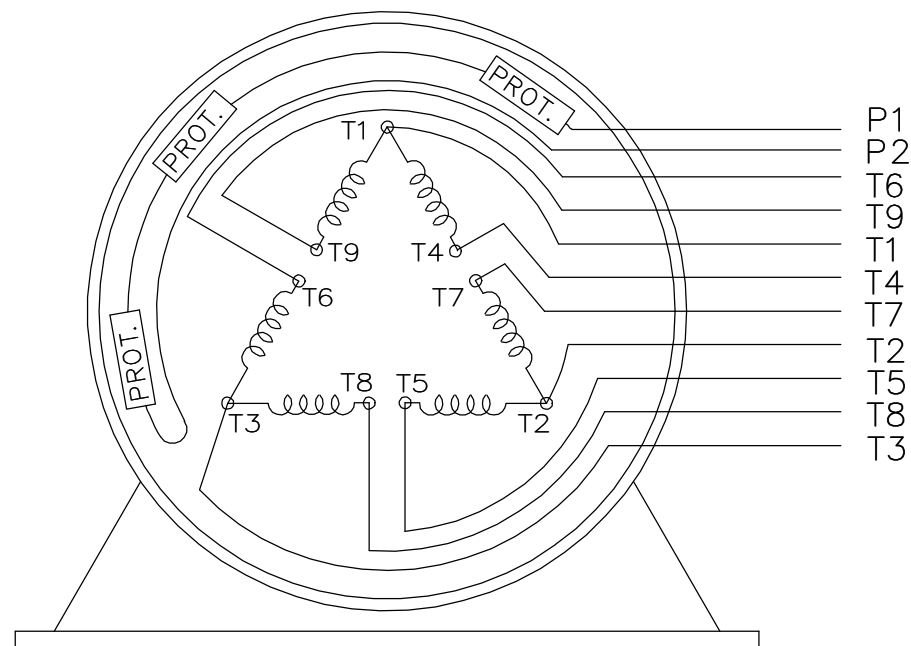
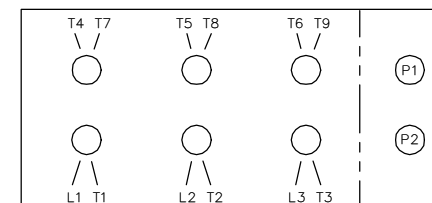

VIEW OF TERMINAL END

WHEN MORE THAN ONE PROT. IS USED; PROT. ARE CONNECTED IN SERIES

DRAWING REVISION L	REVISION BY JP	REV DATE/© DATE 06-21-2019	TOLERANCES (EXCEPT AS NOTED): DEC. INCH mm ANGLE .X ±0.1 [±3] ±7' 30" .XX ±0.02 [±0.5] .XXX ±0.005 [±0.13] .XXXX ±0.0005 [±0.013] REMOVE BURRS & BREAK SHARP EDGES: .003/.015 [.08/.38] X 45° CORNER FILLETS: R.02 [.5] MACHINED SURFACES: 200/ 5.1 INCH mm mm DIMENSIONS IN [BRACKETS] ARE FOR REFERENCE ONLY	DRAWN BY MJD	Regal Beloit America, Inc.
ECO ECO-0168744	APPROVED BY MH	DATE 06-21-2019		DATE 12-19-1997	
ECO DESCRIPTION UPDATED TO CURRENT STANDARDS				APPROVED BY GK	DESCRIPTION CONN DIAGRAM-EXTERNAL
COPYRIGHT (PER REVISION DATE) REGAL BELOIT AMERICA, INC. ALL RIGHTS RESERVED. PROPRIETARY AND CONFIDENTIAL INFORMATION - THIS DOCUMENT IS THE PROPERTY OF REGAL BELOIT AMERICA, INC. ("OWNER") AND CONTAINS OWNER'S PROPRIETARY INFORMATION. ANY PERSON, CORPORATION OR OTHER FIRM RECEIVING IT IS DEEMED, BY RECEIVING IT, TO AGREE THAT IT, AND/OR ANY PART OF IT, SHALL NOT BE DISCLOSED TO ANY PERSON, CORPORATION OR OTHER ENTITY, DUPLICATED, AND/OR USED, EXCEPT AS EXPRESSLY APPROVED IN WRITING IN ADVANCE BY OWNER. THIS DOCUMENT SHALL BE RETURNED TO OWNER UPON REQUEST. IT MAY BE SUBJECT TO CERTAIN RESTRICTIONS UNDER APPLICABLE EXPORT CONTROL LAWS AND REGULATIONS.				DATE 01-07-1998	
			REFERENCE	MATERIAL	PROCESS/FINISH
			THIRD ANGLE PROJECTION	SIZE A	DRAWING NUMBER EE7308AD
					SHEET 1 OF 1

** Subject to change without notice.

